

pro^{sense}® FMM Series (-1002) Magnetic-Inductive Flow Meters

Overview



Part No. FMM75-1002



Part No. FMM200-1002

AutomationDirect's ProSense FMM Series (-1002) Magmeters are designed to reliably detect the flow rate of conductive media up to 158.5 gallons per minute. The stainless steel, mechanically-robust design mounts directly in-line providing a compact, low-profile installation for process control. A 4-digit numeric display with pushbutton setup indicates flow rate and fluid temperature with selectable engineering units. Two outputs are available to remotely monitor the analog status of flow rate and temperature parameters. Simple to set up, easy to install and with no moving parts, the FMM series is a reliable alternative to traditional flow meters and mechanical flow switches.

Features

- 1/2 to 2" NPT female process connections
- Measure up to 158.5 GPM
- Measure fluid temperature in addition to flow
- 4-digit numeric display with pushbutton setup
- Selectable engineering units: GPM, GPH, LPM, m³/h, °F, °C
- Two analog output signals
- 4-pin M12 quick disconnect
- 5-year warranty



Output Function Selections

Output 1:
Analog temperature

Output 2:
Analog flow rate

ProSense FMM Series (-1002) Magnetic Flow Meters					
Model	FMM50-1002	FMM75-1002	FMM100-1002	FMM150-1002	FMM200-1002
Price	\$460.00	\$499.00	\$550.00	\$825.00	\$890.00
Weight	1.14 lb	1.23 lb	1.36 lb	6.76 lb	6.76 lb
Range	0 to 6.6 GPM	0 to 13.2 GPM	0 to 26.4 GPM	0 to 79.3 GPM	0 to 158.5 GPM
Process Connection	1/2" FNPT	3/4" FNPT	1" FNPT	1-1/2" FNPT	2" FNPT
Application	Conductive liquids: ≥ 20 µS/cm (micro Siemens per centimeter) liquids / viscosity: < 70cSt (centiStoke) at 104°F				
Pressure Rating	232PSIG [16bar]				
Medium Temperature	14 to 158°F [-10 to 70°C]				
Operating Voltage	20 to 30VDC			18 to 32VDC	
Current Consumption	120mA			< 150mA	
Insulation Resistance	> 100MΩ (500VDC)				
Protection Class	III				
Reverse Polarity Protection	YES				
Output Functions					
Output Type / Function	OUT1: analog signal / temperature OUT2: analog signal / flow				
Analog Output	4-20 mA max 22mA Max. load: 500Ω (4-20 mA) Overload protection: Yes				
Flow Rate Monitoring					
Measuring Range	0.030 to 6.600 GPM	0.020 to 13.200 GPM	0.100 to 26.400 GPM	1.300 to 79.300 GPM	1.300 to 158.500 GPM
Display Range	-7.920 to 7.920 GPM	-15.860 to 15.860 GPM	-31.700 to 31.700 GPM	-95.100 to 95.100 GPM	-190.200 to 190.200 GPM
Resolution	0.010 GPM	0.020 GPM	0.050 GPM	0.100 GPM	0.100 GPM
Analog Start Point, ASP	0.000 to 5.280 GPM	0.000 to 10.580 GPM	0.000 to 21.100 GPM	0.000 to 63.400 GPM	0.000 to 126.800 GPM
Analog End Point, AEP	1.320 to 6.600 GPM	2.640 to 13.220 GPM	5.300 to 26.400 GPM	15.900 to 79.300 GPM	31.700 to 158.500 GPM
In Steps Of	0.010 GPM	0.020 GPM	0.050 GPM	0.100 GPM	0.100 GPM

pro^{sense}® FMM Series (-1002) Magnetic-Inductive Flow Meters

ProSense FMM Series (-1002) Magnetic Flow Meters					
Model	FMM50-1002	FMM75-1002	FMM100-1002	FMM150-1002	FMM200-1002
Temperature Monitoring					
Measuring Range	-4 to 176°F [-20 to 80°C]				
Resolution	0.5°F [0.2°C]				
Analog Start Point, ASP	-4.0 to 140°F [-20 to 60°C]				
Analog End Point, AEP	32 to 176.0°F [0.0 to 80°C]				
In Steps Of	0.5°F [0.28°C]				
Accuracy / Deviations					
Flow Monitoring					
Accuracy¹	± (2% MW + 0.5% VMR)			± (0.8% MW + 0.5% VMR)	
Repeatability¹	± 0.2% VMR				
Temperature Monitoring					
Accuracy	± 2.5°K (Q > 0.26 GPM)			± 1°K (Q > 4.00 GPM)	
Reaction Times					
Power-On Delay Time	5s				
Flow Monitoring					
Response Time	< 0.150s (dAP = 0)			< 0.350s (dAP = 0)	
Display Damping, dAP	0.0 to 3.0s			0.0 to 5.0s	
Temperature Monitoring					
Response Time	T09 = 3s (Q > 4.00 GPM)				
Environment					
Ambient Temperature	14 to 140°F [-10 to 60°C]				
Storage Temperature	-13 to 176°F [-25 to 80°C]				
Protection	IP 67			IP 65, IP 67	
Mechanical Data					
Process Connection	1/2" NPT female	3/4" NPT female	1" NPT female	1-1/2" NPT female	2" NPT female
Materials (wetted parts)	Stainless steel 316L / 1.4404; PEEK (polyether ether ketone); FKM			Stainless steel 316L / 1.4404; stainless steel 316Ti / 1.4571; PEEK (polyether ether ketone); Hastelloy C-4 (2.4610); Cetellen: FKM	
Housing Materials	Stainless steel 316L / 1.4404; PBT-GF 20; PC; EPDM/X			Stainless steel 316L / 1.4404; stainless steel 316Ti / 1.4571; PEI; FKM; PBT-GF 20; elastolan	
Displays / Operating Elements					
Display	Display unit: Measured values: Programming:	6 x LED green (l/min, m ³ /h, GPM, GPH, °C, °F) 4-digit alphanumeric display (7.5 mm) 4-digit alphanumeric display (7.5 mm)		Display unit: Function display: Measured values: Programming:	6 x LED green (l/min, m ³ /h, GPM, GPH, °C, °F) 1 x LED yellow (10 ²) 4-digit alphanumeric display (7.5 mm) 4-digit alphanumeric display (7.5 mm)
Electrical Connection					
Connection	M12 connector; gold-plated contacts				
Tests / Approvals					
EMC	EN 61000-4-2: 4kV CD / 8kV AD EN 61000-4-3 HF radiated: 10 V/m EN 61000-4-4 Burst: 2kV EN 61000-4-5 Surge: 0.5 kV EN 61000-4-6 HF conducted: 10V				
Shock Resistance	DIN IEC 68-2-27: 20g (11ms)				
Vibration Resistance	DIN IEC 68-2-6: 5g (10 to 2,000Hz)				
Approvals*	UL (E320431), CE, RoHS				
* To obtain the most current agency approval information, see the Agency Approval Checklist section on the specific part number's web page at www.automationdirect.com					
¹ MW = Measured value; VMR = Final value of the measuring range					



NOTE: CHECK THE CHEMICAL COMPATIBILITY OF THE SENSOR'S WETTED PARTS WITH THE MEDIUM TO BE MEASURED.

pro^{sense}® FMM Series (-1002) Magnetic-Inductive Flow Meters

Wiring Diagram

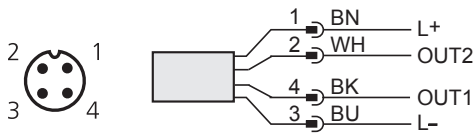

Cable Assembly Wiring Colors:

Pin 1 - Brown

Pin 2 - White

Pin 3 - Blue

Pin 4 - Black

Colors to DIN EN 60947-5-2

For additional wiring details see individual product manuals.

Use FMM-GND1 if meter is installed in ungrounded pipe system.

Output Function Selections

Models:

FMM50-1002, FMM75-1002, FMM100-1002,

FMM150-1002, FMM200-1002

Output 1:

Analog temperature

Output 2:

Analog flow rate

Note: Wiring colors are based on AutomationDirect CD12L and CD12M 4-pole cable assemblies.

Pressure Loss/Flow Rate*

FMM50-1002

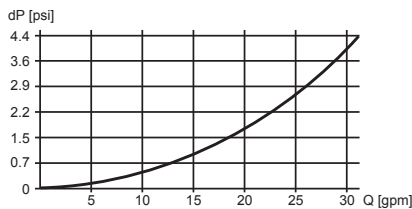

FMM150-1002

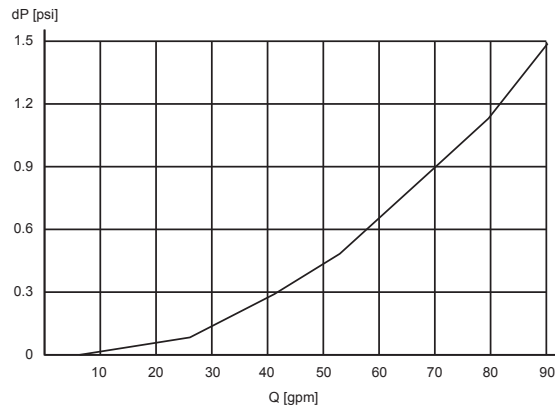

FMM75-1002

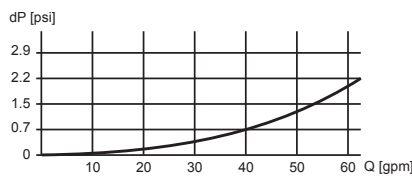

FMM200-1002

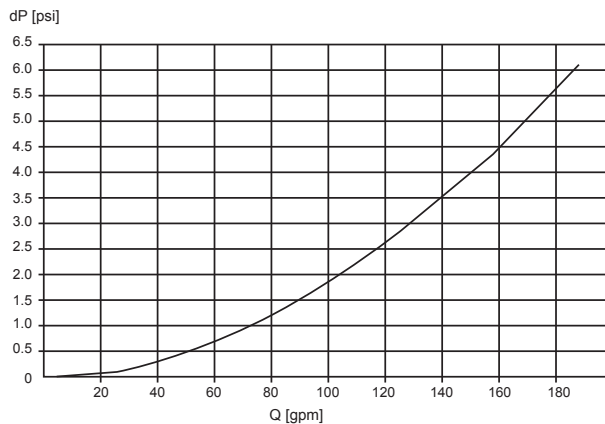

FMM100-1002

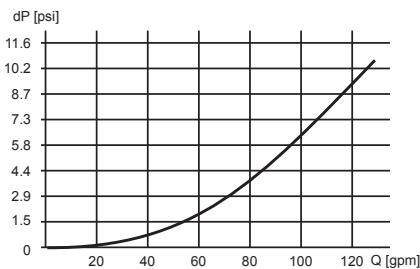

* when used with water @ 68°F [20°C]

pro^{sense}® FMM Series (-1002) Magnetic-Inductive Flow Meters

Company Information

Drives

Soft Starters

Motors

Power Transmission

Motion: Servos and Steppers

Motor Controls

Sensors: Proximity

Sensors: Photoelectric

Sensors: Encoders

Sensors: Limit Switches

Sensors: Current

Sensors: Pressure

Sensors: Temperature

Sensors: Level

Sensors: Flow

Pushbuttons and Lights

Stacklights

Signal Devices

Process

Relays and Timers

Pneumatics: Air Prep

Pneumatics: Directional Control Valves

Pneumatics: Cylinders

Pneumatics: Tubing

Pneumatics: Air Fittings

Appendix Book 2

Terms and Conditions

Dimensions

mm [inches]

Part No. FMM50-1002

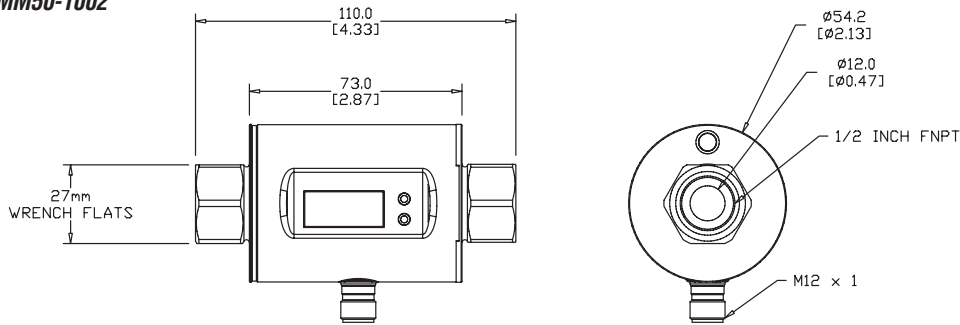

Part No. FMM75-1002

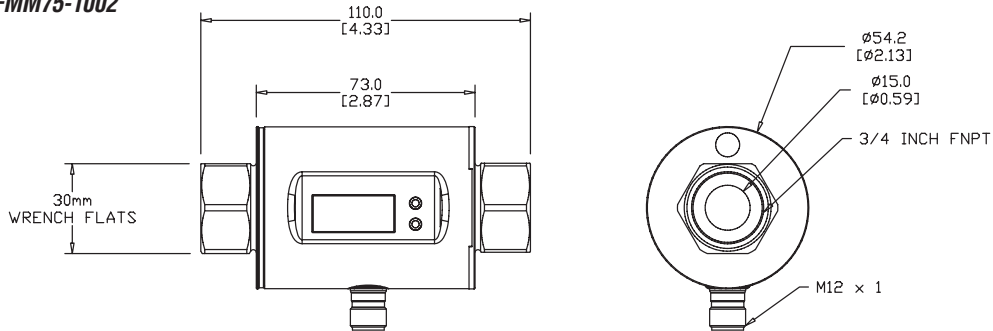

Part No. FMM100-1002

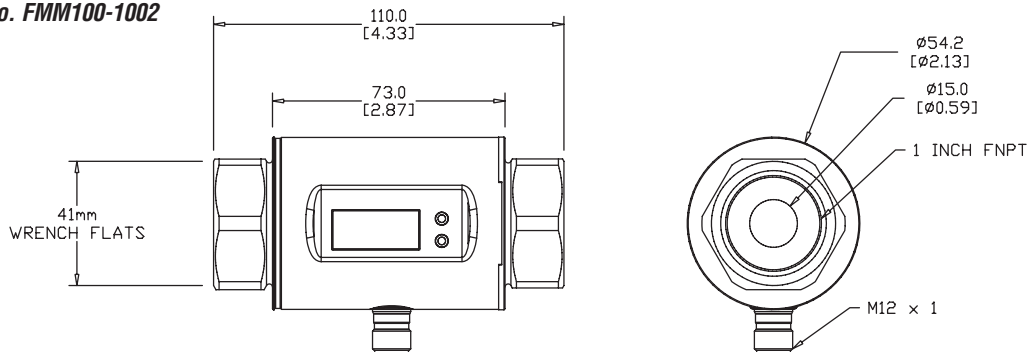

See our website www.AutomationDirect.com for complete Engineering drawings.

pro^{sense}® FMM Series (-1002) Magnetic-Inductive Flow Meters

Dimensions

mm [inches]

Part No. FMM150-1002

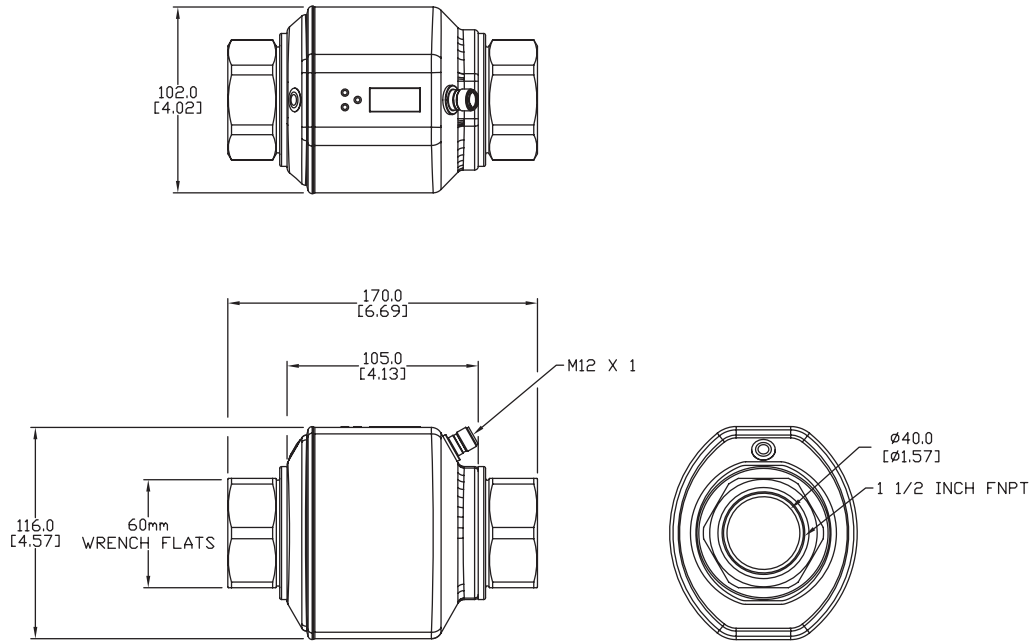

Part No. FMM200-1002

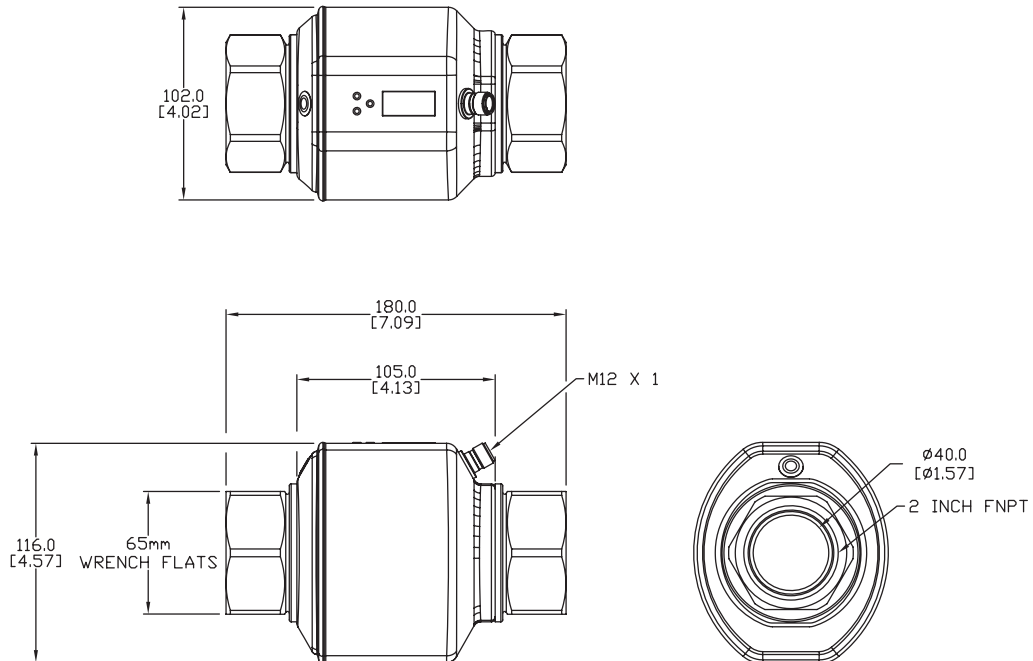

See our website www.AutomationDirect.com for complete Engineering drawings.

pro^{sense}® Magnetic-Inductive Flow Meter Accessories



The FMM-GND1 Grounding Clamp is used when an FMM series Magnetic-Inductive Flow Meter is installed in an ungrounded pipe system (e.g. PVC pipe).

Simply place the FMM-GND1 Grounding Clamp around the base of the M12 connector and attach a grounded wire to FMM-GND1 Grounding Clamp with the supplied machine screw and nut.

Note: Improper grounding may cause inaccurate readings

ProSense Magnetic Flow Meter Accessories			
Part No.	Description	Price	Weight
FMM-GND1	ProSense 316 stainless steel grounding clamp for magnetic flow meters with an M12 connector.	\$6.00	0.015 lb

Dimensions

mm [inches]

Part No. FMM-GND1

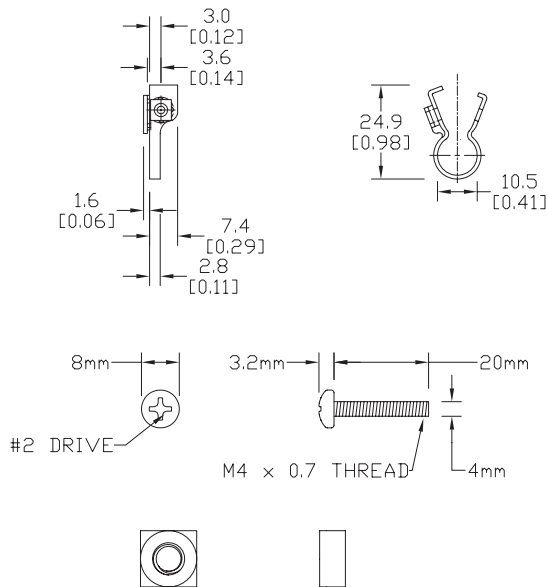

Grounding Clamp Installation

The ProSense magnetic flow meter grounding clamp is installed as shown above.

Note: the ground wire shown above is not included.

See our website www.AutomationDirect.com for complete Engineering drawings.

Company Information

Drives

Soft Starters

Motors

Power Transmission

Motion: Servos and Steppers

Motor Controls

Sensors: Proximity

Sensors: Photoelectric

Sensors: Encoders

Sensors: Limit Switches

Sensors: Current

Sensors: Pressure

Sensors: Temperature

Sensors: Level

Sensors: Flow

Pushbuttons and Lights

Stacklights

Signal Devices

Process

Relays and Timers

Pneumatics: Air Prep

Pneumatics: Directional Control Valves

Pneumatics: Cylinders

Pneumatics: Tubing

Pneumatics: Air Fittings

Appendix Book 2

Terms and Conditions

pro^{sense}® FMM Series Magnetic-Inductive Flow Meters



Magnetic-Inductive Flow Meter Application

Magnetic-inductive flow meters (Magmeters) are one of the most widely used technologies for liquid flow monitoring in industrial process markets such as wastewater, mining and minerals, utilities, food and beverage, and pharmaceuticals. To ensure reliable and accurate operation, some important application requirements should be considered. Meeting the minimum conductivity of the liquid and properly installing with a full pipe are required in order to avoid significant error or the

meter not functioning at all. Additionally, the presences of air bubbles should be avoided as they will affect the accuracy of the meter's measurements. Installation location in the piping is important because disturbances in the flow caused by bends in the pipe, valves, reductions, etc. can cause inaccuracies. Refer to the magmeter's specifications and operating instruction documents for specific information regarding application and installation requirements.

Magnetic-Inductive Flow Meter Measuring Principle

Magmeters operate by using the magnetic-inductive measuring principle in which a magnetic field is generated in the specified measuring pipe by current-carrying coils. When the media flows through the pipe, the ions of the conductive media are diverted perpendicularly to the magnetic field with the positive and negative charge carriers flowing in opposite directions. The two electrodes that are in contact with

the medium then measure the voltage that is induced. The measured signal voltage is proportional to the average flow velocity. By knowing the inside pipe diameter of the unit, the volumetric flow rate is determined. Magmeters are suitable for use with a variety of conductive liquids in industrial process applications such as those in the following graph:

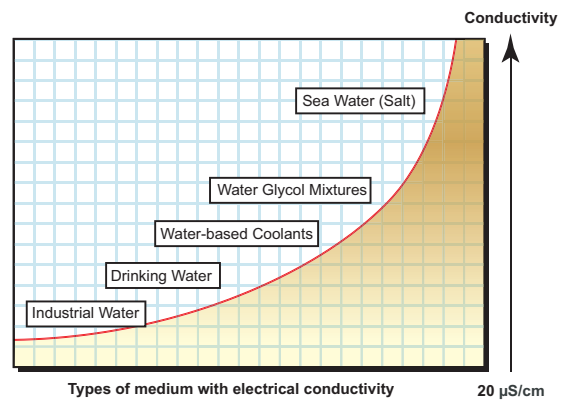
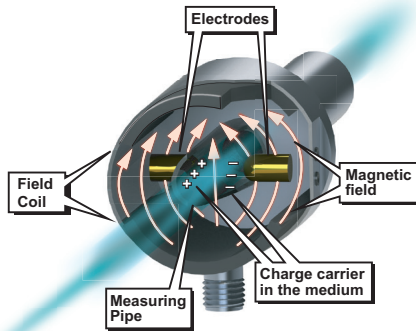

ProSense FMM Series Magnetic Flow Meter Selection Guide											
Model	Price	Process Connection	Flow Range	Temperature Range	Display Units	Output 1	Output 2	Empty Pipe Detection			
FMM50-1001	\$460.00	1/2" FNPT	0 to 6.6 GPM	-4 to 176°F [-20 to 80°C]	GPM, GPH, GAL, or °F	Switch or pulse (flow)	Switch, analog or reset input (flow or temperature)	No			
FMM75-1001	\$499.00	3/4" FNPT	0 to 13.2 GPM					Yes			
FMM100-1001	\$550.00	1" FNPT	0 to 26.4 GPM			Switch, pulse or frequency (flow)	Analog 4-20 mA (temperature)	Analog 4-20 mA (flow)	No		
FMM150-1001	\$825.00	1-1/2" FNPT	0 to 80 GPM						Yes		
FMM200-1001	\$890.00	2" FNPT	0 to 160 GPM		GPM, GPH, LPM, m³/h, °F, °C	Analog 4-20 mA (temperature)	Analog 4-20 mA (flow)	No			
FMM50-1002	\$460.00	1/2" FNPT	0 to 6.6 GPM					Switch, pulse or frequency (flow)	Analog 4-20 mA (temperature)	Analog 4-20 mA (flow)	No
FMM75-1002	\$499.00	3/4" FNPT	0 to 13.2 GPM								Switch, pulse or frequency (flow)
FMM100-1002	\$550.00	1" FNPT	0 to 26.4 GPM					Switch, pulse or frequency (flow)	Analog 4-20 mA (temperature)	Analog 4-20 mA (flow)	
FMM150-1002	\$825.00	1-1/2" FNPT	0 to 79.3 GPM								Switch, pulse or frequency (flow)
FMM200-1002	\$890.00	2" FNPT	0 to 158.5 GPM					Yes			