

proSense® FSD Series Flow Switches

The ProSense FSD Series flow switches are ideal for applications with rapid temperature changes or where fast response time is required, such as:

- Machine tool coolant flow
- HVAC cooling water flow
- Injection molding cooling water flow



Part No. FSD75-AP-6H



Part No. FSD1-AP-26H

Overview

The ProSense FSD Series flow switches monitor liquid media and provide reliable flow detection for various flow applications.

The ProSense FSD Series sensing principle ensures extremely fast response time and allows for a more precise setpoint setting. The setpoint can be easily set and locked with a setting screw.

Features

- Monitor 0.26 to 26.4 GPM (gallons per minute) in 2 models
- Immune to rapid temperature changes of media
- Fast response time of 10ms: great for cycling applications with a minimum of 10 million switching cycles
- Easy to set: turn dial to desired setpoint
- Able to be bench set outside the process
- 3/4" or 1" FNPT process connections
- Integrated check valve design allows the sensor to be mounted horizontally or vertically
- 4-pin M12 quick disconnect
- IP65 / IP67
- LED output status indication
- 2-year warranty



#E320431

ProSense FSD Series Flow Switches				
Part No.	Description	Quantity	Weight (lbs)	Price
FSD75-AP-6H	24VDC, 0.26 to 6.6 GPM setpoint range, rotating dial adjustment with lock screw, 26.4 GPM max flow rate, nickel-plated brass housing with 3/4 in. FNPT process connections, N.O. DC PNP output. Cable sold separately.	1	1.0	\$125.00
FSD1-AP-26H	24VDC, 1.32 to 26.4 GPM setpoint range, rotating dial adjustment with lock screw, 52.8 GPM max flow rate, nickel-plated brass housing with 1 in. FNPT process connections, N.O. DC PNP output. Cable sold separately.	1	1.6	\$150.00

ProSense FSD Series Flow Switches Technical Specifications		
Model	FSD75-AP-6H	FSD1-AP-26H
Operating Voltage	20.4 to 26.4 VDC (must use a Class 2 power supply in order to comply with UL508 requirements)	
Electrical Connection	M12 (note: tightening torque < 0.6 Nm based on cable)	
Connection Pin Material	Gold-plated	
Output Function	Normally open (PNP)	
Output Maximum Load Current	100mA	
Current Consumption	< 15mA	
Voltage Drop	< 2.5 VDC	
Short-Circuit Protection	YES	
Reverse Polarity Protection	YES	
Overload Protection	YES	
Switching Cycles Minimum	10 million	
Response Time	10ms	
Accuracy*	± 5% of full range	
Repeatability	0.06 GPM	0.26 GPM
Process Connection	3/4" FNPT	1" FNPT
Medium	liquids (water, glycol solutions, oils)	
Maximum Flow Rate	< 26.4 GPM	< 52.8 GPM
Setpoint Range	0.26 - 6.6 GPM	1.32 - 26.4 GPM
Hysteresis	0.13 - 0.53 GPM	0.8 - 1.58 GPM
Pressure Rating	362PSI	

* when used with water

pro^{sense}® FSD Series Flow Switches

Company Information

Drives

Soft Starters

Motors

Power Transmission

Motion: Servos and Steppers

Motor Controls

Sensors: Proximity

Sensors: Photoelectric

Sensors: Encoders

Sensors: Limit Switches

Sensors: Current

Sensors: Pressure

Sensors: Temperature

Sensors: Level

Sensors: Flow

Pushbuttons and Lights

Stacklights

Signal Devices

Process

Relays and Timers

Pneumatics: Air Prep

Pneumatics: Directional Control Valves

Pneumatics: Cylinders

Pneumatics: Tubing

Pneumatics: Air Fittings

Appendix Book 2

Terms and Conditions

ProSense FSD Series Flow Switches Environmental Specifications

Model	FSD75-AP-6H	FSD1-AP-26H
Housing Material	brass chemically nickel-plated; aluminum anodized; POM	
Materials (wetted parts)	Stainless steel (304S15); brass chemically nickel-plated; PP (Polypropylene); POCAN PBT (Polybutylene terephthalate); O-ring:FPM (Viton)	
Operating Temperature	32 to 140°F (0 to 60°C)	
Medium Temperature	32 to 185°F (0 to 85°C)	
Storage Temperature	-40 to 212°F (-40 to 100°C)	
Protection	IP65 / IP67	
Protection Class	III	
Agency Approvals	cULus (#E320431), CE, RoHS	



NOTE: CHECK THE CHEMICAL COMPATIBILITY OF THE SENSOR'S WETTED PARTS WITH THE MEDIUM TO BE MEASURED.

Wiring Diagrams

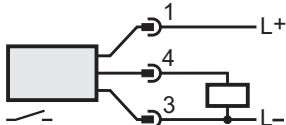

Cable Assembly Wiring Colors:

- Pin 1 - Brown
- Pin 2 - White
- Pin 3 - Blue
- Pin 4 - Black

Note: Wiring colors are based on AutomationDirect CD12L and CD12M 4-pole cable assemblies.

LED Functions

The FSD units monitor the flow of liquid media such as: water, glycol solutions, and oils. The LED functions are as follows:

- Output closed (LED = ON), if volumetric flow quantity \geq setpoint.
- Output open (LED = OFF), if volumetric flow quantity $<$ setpoint.

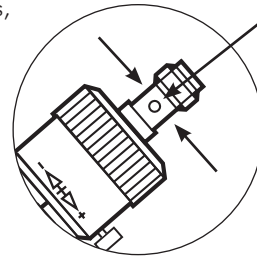

There are 4 LEDs (one on each side) on the top connector for easy visibility regardless of installation orientation.

Installation*:

For proper flow switch operation, the sensor should be installed as indicated in the Illustrations below (noting the flow direction arrow on the body of the sensor):

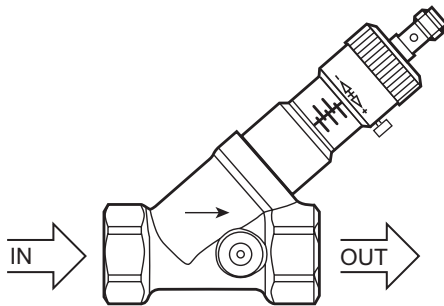

Horizontal Mounting

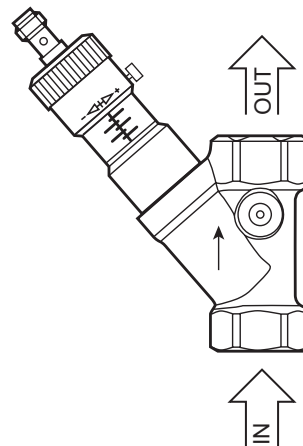

Vertical Mounting

* Integral check valve design allows the sensor to be mounted in any position (horizontally or vertically).

pro^{sense}® FSD Series Flow Switches

Pressure Loss/Flow Rate*

FSD75-AP-6H

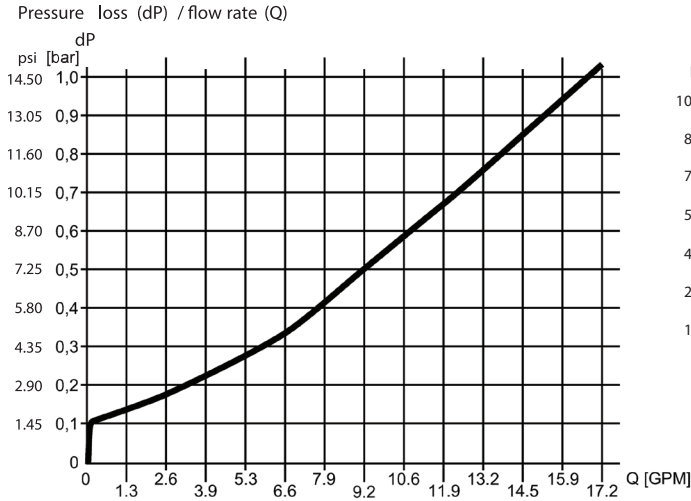

FSD1-AP-26H

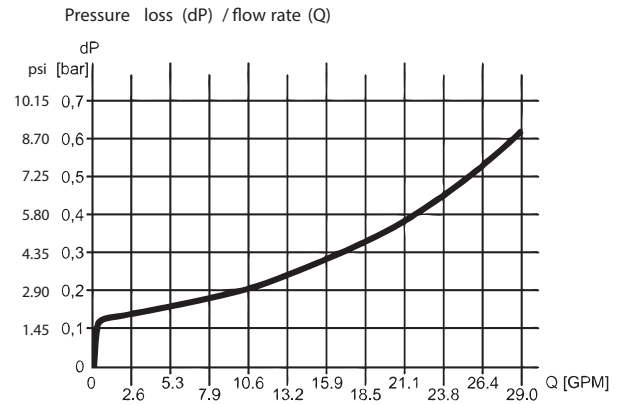

* when used with water

Dimensions

mm [inches]

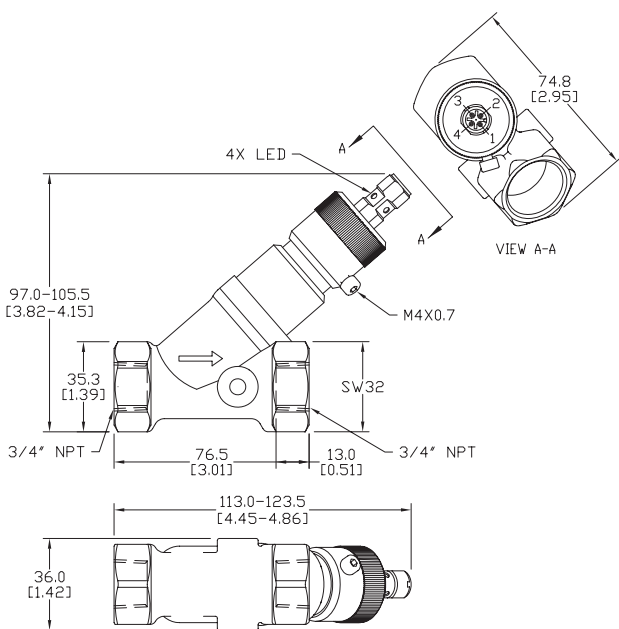

Part No. FSD75-AP-6H

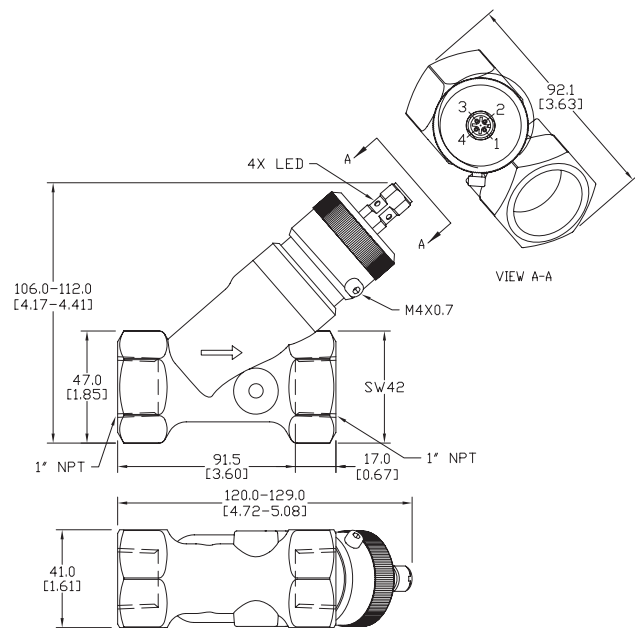

Part No. FSD1-AP-26H

prosense® FSD Series Flow Switches

Operation & Setting

The flow sensor utilizes a spring-supported piston that is lifted by the flowing medium. The piston position is detected via an inductive sensor and is output as a binary signal. The spring resets the piston to its initial position with decreasing flow. This allows the sensor to be mounted in any position (horizontally or vertically) and function as a check valve.

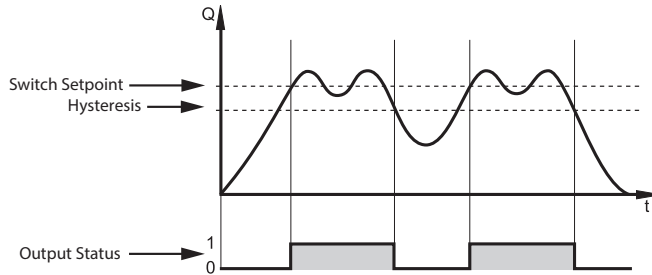

Note: Hysteresis varies based on switch setpoint.



Cutaway View

Setting FSD Series flow switches is quick and easy. There are two ways to set the flow switches - using a desired flow value and adjustment to existing flow.

Setting the ProSense FSD using a desired flow value

1. Loosen the locking screw.
2. Set the switching point by rotating the Setpoint dial until the desired flow value just becomes visible on the setting scale.
3. Tighten the locking screw.

Example in Figure 1: desired value = 2 GPM

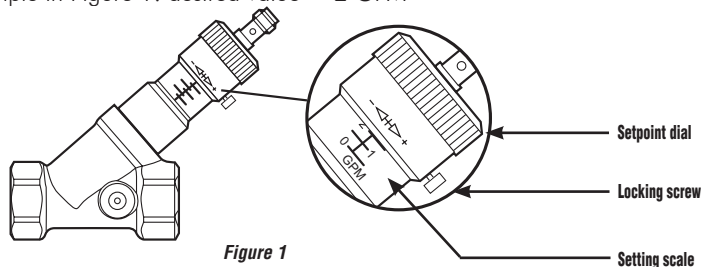

Figure 1

Adjustment to existing flow

1. Let the normal flow circulate in the installation.
2. Loosen the locking screw.
3. Set the switching point by rotating the Setpoint dial.
 - If the LED lights before setting: turn the Setpoint dial in the direction [+] until the LED goes out. Then turn in the opposite direction [-] until the LED lights.
 - If the LED does not light before setting: turn the Setpoint dial in the direction [-] until the LED lights.
4. Tighten the locking screw.

Correlation between the number of turns of the Setpoint dial and the switching point is that one complete turn of the Setpoint dial corresponds to an approximate gallons per minute rate. This is shown in the table below:

Part Number	Gallons/Minute	Max. Gallons/Minute*
FSD75-AP-6H	0.8 GPM	6.6 GPM
FSD1-AP-26H	3.3 GPM	26.4 GPM



***DO NOT TURN THE SETTING SCREW BEYOND THE MAXIMUM VALUE OF THE SETTING RANGE TO AVOID FAULTY SWITCHING.**