

Light-duty Incremental Encoders (SAE-dimension Encoders)

TRDA-2E series

Features

A light-duty encoder that is cost-effective for small applications; has the following features:

- Small body with 1.5 in. diameter and 1.6 in. depth
- 0.25 in. diameter solid shaft
- Resolution available from 100 pulses per revolution to 2500 pulses per revolution
- Open collector or line driver output
- Up to 200 kHz response frequency
- Two-meter cable with tinned ends
- IP50 environmental rating



TRDA-2Exxx-BD models



TRDA-2Exxx-VD models

Incremental Light-duty Solid-shaft Encoders (NPN Open-collector Output, TRDA-2ExxxBD)					
Part Number	Price	Pulses per Revolution	Input Voltage	Output	Body Dia.
TRDA-2E100BD	<-->	100	12–24 VDC	NPN Open Collector	1.5 in.
TRDA-2E360BD	<-->	360			
TRDA-2E500BD	<-->	500			
TRDA-2E1000BD	<-->	1000			
TRDA-2E1024BD	<-->	1024			
TRDA-2E2500BD	<-->	2500			

Incremental Light-duty Solid-shaft Encoders (Line-driver Output, TRDA-2ExxxVD)					
Part Number	Price	Pulses per Revolution	Input Voltage	Output	Body Dia.
TRDA-2E100VD	<-->	100	5VDC	Line Driver (differential)	1.5 in.
TRDA-2E360VD	<-->	360			
TRDA-2E500VD	<-->	500			
TRDA-2E1000VD	<-->	1000			
TRDA-2E1024VD	<-->	1024			
TRDA-2E2500VD	<-->	2500			

Accessories

Accessories for TRDA-2E Series Encoders		
Part Number	Price	Description
F-2D	<-->	Mounting flange for TRDA-2E series encoders, NEMA23 mounting dimensions (height 1.05 in.)
F-3D	<-->	Mounting flange for TRDA-2E series encoders, NEMA34 mounting dimensions
F-6D	<-->	Mounting flange for TRDA-2E series encoders, NEMA23 mounting dimensions (height 1.34 in.)
F-7D	<-->	Mounting flange for TRDA-2E series encoders, 1 inch bolt-hole circle
F-8D	<-->	Mounting flange for TRDA-2E series encoders, NEMA42 mounting dimensions
2ET-035D	<-->	Mounting bracket for TRDA-2E series encoders

Couplings

For encoders with a solid shaft, please select a coupling that fits your encoder. All couplings are in stock, ready to ship. See the “Encoder Couplings” section for more information.



2ET-035D



F-2D



F-3D



F-6D



F-7D



F-8D

Light-duty Incremental Encoders (SAE-dimension Encoders)

Specifications – TRDA-2E series

Electrical Specifications (SAE-dimension Light Duty)				
Model		TRDA-2ExxxBD (open collector)	TRDA-2ExxxVD (line driver)	
Power Supply	Operating Voltage *	12–24 VDC (nominal) * Range: 10.8–26.4 VDC	5VDC (nominal) * Range: 4.75–5.25 VDC	
	Allowable Ripple	3% rms max.		
	Current Consumption	50 mA max. no load		
Output Waveform	Signal Waveform	Quadrature + home position		
	Max. Response Frequency	200 kHz		
	Operating Speed	(max response frequency / resolution) x 60		
	Duty Ratio (Symmetry)	50% ±25%		
	Index Signal Width (at Home Position)	100% ±50%		
Output	Rise/Fall Time **	1µs max. **	100 ns max. **	
	Output Type	Open collector (NPN sinking)	Line driver (26C31 or equivalent)	
	Output Logic	Negative logic (active low)	Positive logic (active high)	
	Output Current	Inflow	30 mA max.	20 mA max.
		Outflow	–	
	Output Voltage	H	–	2.5V min.
		L	0.4V max.	0.5V max.
	Load Power Supply Voltage	30 VDC max.		–
Short-circuit Protection	Between each output and 0V		–	
* To be supplied by Class II source. ** With a cable of 2m or less; Max load.				
Mechanical Specifications				
Starting Torque	0.01 N·m [0.09 lb·in] max. @ 20 °C [68 °F]			
Max. Allowable Shaft Load	Axial: 20N [4.5 lb]; Radial: 30N [6.7 lb]			
Max. Allowable Speed	5000 rpm (highest speed that can support the mechanical integrity of encoder)			
Wire Size	26 AWG, shielded, oil-resistant PVC			
Mounting Orientation	can be mounted in any orientation			
Weight	approx. 170g [6.0 oz] (with 2m cable)			
Environmental Specifications				
Ambient Temperature	-10 to 70 °C [-14 to 158 °F]			
Storage Temperature	-25 to 85 °C [-13 to 185 °F]			
Operating Humidity	35–85% RH (non-condensing)			
Voltage Withstand	630V grounded through capacitor (a 630V cap is connected between 0V & FG lines)			
Insulation Resistance	50 MΩ min. (excluding shield)			
Vibration Resistance	durable for one hour along three axes @ 10 to 55 Hz with 0.75 mm half-amplitude			
Shock Resistance	490 m/s ² (11 ms applied three times along three axes)			
Protection	IP50			
Agency Approvals	CE, RoHS, cUL _{US} (E189395)			

Light-duty Incremental Encoders (SAE-dimension Encoders)

Specifications – TRDA-2E series

Wiring Diagrams

Open Collector Connections

Cable shield is connected to the encoder body (frame ground)



Line Driver Connections

Cable shield is connected to the encoder body (frame ground)

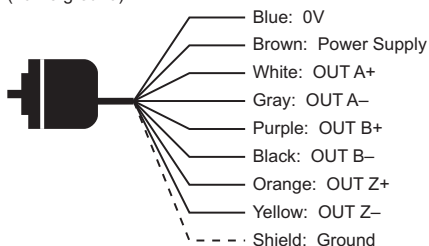

How to read the timing charts

Open Collector Models

Out A and Out B are 90 degrees out of phase. Like any quadrature encoder, four unique logic states are created internally to the encoder. This is based on the rising edge to rising edge (one cycle) on channel A or B that indicates one set of bars on the internal encoder disk has passed by the optical sensor.

OUT Z is the absolute reference added to an incremental encoder and is also known as home position. It signifies a full rotation of the encoder shaft.

Line Driver Models

Channel A (OUT A and A-not) and Channel B (OUT B and B-not) are also 90 degrees out of phase on line driver encoders. OUT Z is the same as on open collector models, and is the absolute reference (home position). It signifies one full rotation of the encoder shaft.

Channel Timing Charts

Open Collector Models (TRDA-2ExxxBD)

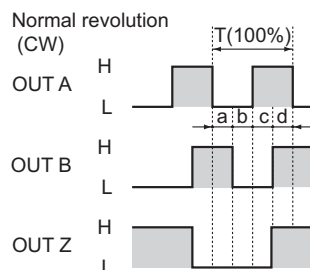

$a, b, c, d = 1/4T \pm 1/8T$

"Normal" means clockwise revolution viewed from the shaft

Line Driver Models (TRDA-2ExxxVD)

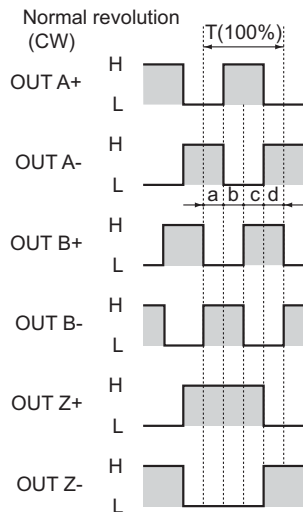

$a, b, c, d = 1/4T \pm 1/8T$

"Normal" means clockwise revolution viewed from the shaft

Light-duty Incremental Encoders (SAE-dimension Encoders)

Dimensions – TRDA-2E series

Dimensions = in [mm]

TRDA-2ExxxxD

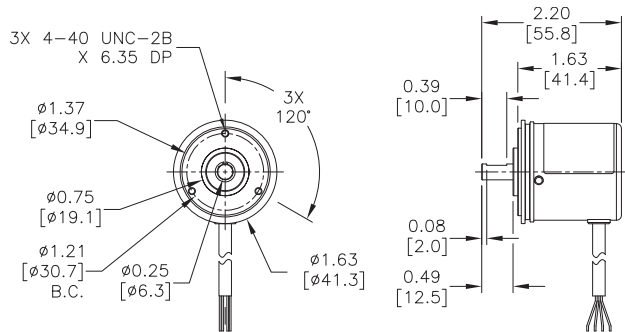

2ET-035D Mounting Bracket

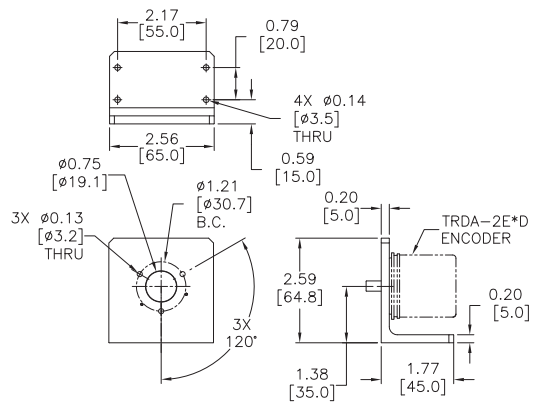

F-2D Mounting Flange

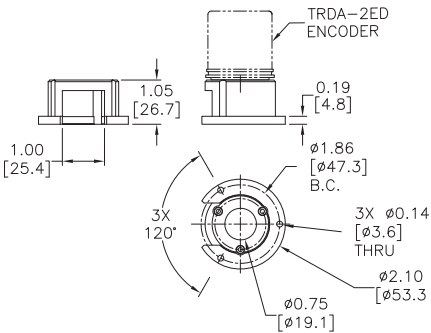

F-7D Mounting Flange

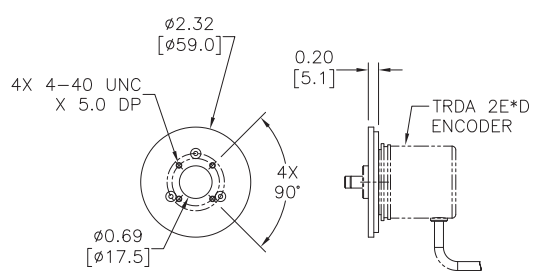

F-3D Mounting Flange

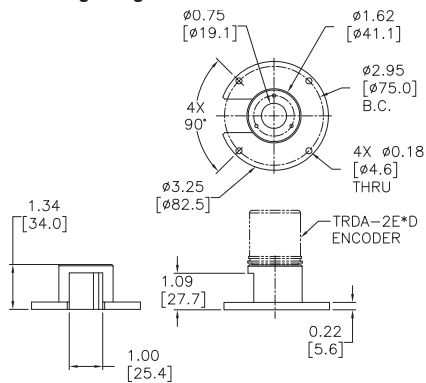

F-8D Mounting Flange

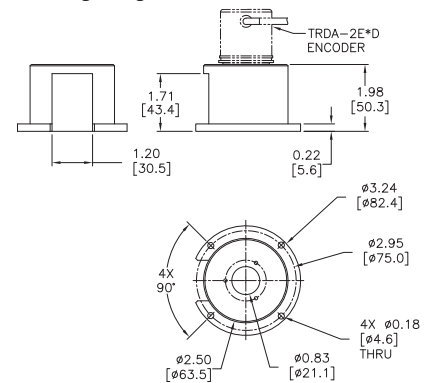

F-6D Mounting Flange

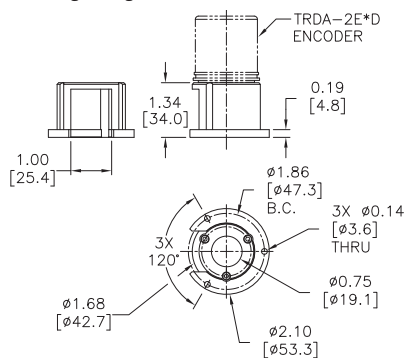

Light-duty Incremental Encoders (Metric-dimension Encoders)

TRD-MX series

Features

A light-duty incremental rotary encoder that is a cost-effective encoder for small applications; has the following features:

- Small body with 25 mm diameter and 29 mm depth
- 4 mm diameter solid shaft
- Resolution available from 100 pulses per revolution to 1024 pulses per revolution
- Open collector output (4.5–13.2 or 10.8–26.4 VDC), or line driver output (4.75–5.25 VDC)
- Up to 100 kHz response frequency
- Two-meter cable with tinned ends
- IP50 environmental rating
- Mounting bracket and couplings are available



TRD-MXxxx-AD/BD models



TRD-MXxxx-VD models

Light-duty Solid-shaft Incremental Encoders (NPN Open-collector Output, TRD-MXxxxAD/BD)					
Part Number	Price	Pulses per Revolution	Input Voltage	Output	Body Dia.
TRD-MX100AD	<--->	100	4.5–13.2 VDC	NPN Open Collector	25 mm
TRD-MX360AD	<--->	360			
TRD-MX500AD	<--->	500			
TRD-MX1000AD	<--->	1000			
TRD-MX1024AD	<--->	1024			
TRD-MX100BD	<--->	100	10.8–26.4 VDC	NPN Open Collector	25 mm
TRD-MX360BD	<--->	360			
TRD-MX500BD	<--->	500			
TRD-MX1000BD	<--->	1000			
TRD-MX1024BD	<--->	1024			

Light-duty Solid-shaft Incremental Encoders (Line Driver Output, TRD-MXxxxVD)					
Part Number	Price	Pulses per Revolution	Input Voltage	Output	Body Dia.
TRD-MX100VD	<--->	100	4.75–5.25 VDC	Line Driver	25 mm
TRD-MX360VD	<--->	360			
TRD-MX500VD	<--->	500			
TRD-MX1000VD	<--->	1000			
TRD-MX1024VD	<--->	1024			

Accessories

Accessories for TRD-MX Series Encoders		
Part Number	Price	Description
MM-4D	<--->	Servo mounting clamp for TRD-MX series encoders
MT-030D	<--->	Right-angle mounting bracket for TRD-MX series encoders



MM-4D



MT-030D

Couplings

For encoders with a solid shaft, please select a coupling that fits your encoder. All couplings are typically in stock, and ready to ship.

See the “Encoder Couplings” section for more information.



Couplings

Light-duty Incremental Encoders (Metric-dimension Encoders)

Specifications – TRD-MX series

Electrical Specifications (Metric-dimension Light-duty TRD-MX)					
Model		TRD-MXxxxAD (open collector)	TRD-MXxxxBD (open collector)	TRD-MXxxxVD (line driver)	
Power Supply	Operating Voltage *	5–12 VDC (nominal) * 4.5–13.2 VDC	12–24 VDC (nominal) * 10.8–26.4 VDC	5VDC (nominal) * 4.75–5.25 VDC	
	Allowable Ripple	3% rms max			
	Current Consumption	50 mA max (no load)			
	Circuit Protection Required	Limit current to 100 mA or less		–	
Output Waveform	Signal Waveform	Quadrature + home position			
	Max. Response Frequency	100 kHz			
	Operating Speed	(max response frequency / resolution) x 60 Hz			
	Duty Ratio (Symmetry)	50% ±25%			
	Index Signal Width (at Home Position)	100% ±50%			
Output	Rise/Fall Time **	2µs ** (sink current < 30 mA)		0.1 µs max ** (source current < 20 mA)	
	Output Type	Open collector (NPN sinking)		Line driver (26C31 or equivalent)	
	Output Logic	Negative logic (active low)		Positive logic (active high)	
	Output Current	Inflow	30 mA max		20 mA max
		Outflow	–		
	Output Voltage	H	–		2.5V min (source current < 20 mA)
		L	0.4V max (sink current < 30 mA)		0.5V max (source current < 20 mA)
	Load Power Voltage	30 VDC max		–	–
Short-circuit Protection	–		–	–	
* To be supplied by Class II source. ** Cable length 2m or less. Maximum load.					
Mechanical Specifications (Metric-dimension Light-duty TRD-MX)					
Starting Torque	0.001 N·m [0.009 lb·in] max @ 20 °C [68 °F]				
Max. Allowable Shaft Load	Axial: 5N [1.1 lb]; Radial: 10N [2.2 lb]				
Max. Allowable Speed	6000 rpm (highest speed that can support the mechanical integrity of encoder)				
Wire Size	26 AWG, shielded, oil-resistant PVC				
Weight	approx 120g [0.3 lb]				
Environmental Specifications (Metric-dimension Light-duty TRD-MX)					
Ambient Temperature	-10 to 70 °C [14 to 158 °F]				
Storage Temperature	-25 to 85 °C [-13 to 185 °F]				
Operating Humidity	35–85% RH (non-condensing)				
Withstand Voltage *	630V grounded through capacitor (a 630V cap is connected between 0V & FG lines)				
Insulation Resistance	20 MΩ min				
Vibration Resistance	durable for one hour along three axes @ 10 to 55 Hz with 0.75 mm half-amplitude				
Shock Resistance	490 m/s ² (11 ms applied 3-times, each X, Y, Z)				
Mounting Orientation	can be mounted in any orientation				
Protection	IP50				
Agency Approvals	CE, RoHS, cUL _{US} (E189395)				
* Withstand voltage is good for power supply, signal, and case; not good for shield wire.					

Light-duty Incremental Encoders (Metric-dimension Encoders)

TRD-S(H) series

Features

A light-duty encoder is a cost-effective encoder for small applications and has the following features:

- Small body with 38 mm diameter and 30 mm depth
- Dust proof (IP40 rating)
- 6 mm solid shaft or 8 mm hollow shaft
- Resolution available from 100 pulses per revolution to 2500 pulses per revolution
- Open collector or line driver output
- Up to 200 kHz response frequency
- Two-meter cable, tinned ends



Solid-shaft (TRD-S) model



Hollow-shaft (TRD-SH) model

Light Duty Solid Shaft Incremental Encoders (NPN Open Collector and Line Driver models)						Light Duty Hollow Shaft Incremental Encoders (NPN Open Collector and Line Driver models)					
Part Number	Price	Pulses per Revolution	Input Voltage	Output	Body Diameter	Part Number	Price	Pulses per Revolution	Input Voltage	Output	Body Diameter
TRD-S100-BD	<--->	100	12-24 VDC	NPN open collector	38mm	TRD-SH100-BD	<--->	100	12-24 VDC	NPN open collector	38mm
TRD-S200BD	<--->	200				TRD-SH200BD	<--->	200			
TRD-S250BD	<--->	250				TRD-SH250BD	<--->	250			
TRD-S300BD	<--->	300				TRD-SH300BD	<--->	300			
TRD-S360-BD	<--->	360				TRD-SH360-BD	<--->	360			
TRD-S400BD	<--->	400				TRD-SH400BD	<--->	400			
TRD-S500-BD	<--->	500				TRD-SH500-BD	<--->	500			
TRD-S600BD	<--->	600				TRD-SH600BD	<--->	600			
TRD-S800BD	<--->	800				TRD-SH800BD	<--->	800			
TRD-S1000-BD	<--->	1000				TRD-SH1000-BD	<--->	1000			
TRD-S1024-BD	<--->	1024				TRD-SH1024BD	<--->	1024			
TRD-S1200BD	<--->	1200				TRD-SH1200BD	<--->	1200			
TRD-S2000BD	<--->	2000				TRD-SH2000BD	<--->	2000			
TRD-S2500-BD	<--->	2500				TRD-SH2500-BD	<--->	2500			
TRD-S100-VD	<--->	100	5VDC	Line driver (differential)	38mm	TRD-SH100-VD	<--->	100	5VDC	Line driver (differential)	38mm
TRD-S200VD	<--->	200				TRD-SH200VD	<--->	200			
TRD-S250VD	<--->	250				TRD-SH250VD	<--->	250			
TRD-S300VD	<--->	300				TRD-SH300VD	<--->	300			
TRD-S360-VD	<--->	360				TRD-SH360-VD	<--->	360			
TRD-S400VD	<--->	400				TRD-SH400VD	<--->	400			
TRD-S500-VD	<--->	500				TRD-SH500-VD	<--->	500			
TRD-S600VD	<--->	600				TRD-SH600VD	<--->	600			
TRD-S800VD	<--->	800				TRD-SH800VD	<--->	800			
TRD-S1000-VD	<--->	1000				TRD-SH1000-VD	<--->	1000			
TRD-S1024-VD	<--->	1024				TRD-SH1024VD	<--->	1024			
TRD-S1200VD	<--->	1200				TRD-SH1200VD	<--->	1200			
TRD-S2000VD	<--->	2000				TRD-SH2000VD	<--->	2000			
TRD-S2500-VD	<--->	2500				TRD-SH2500-VD	<--->	2500			

Light-duty Incremental Encoders (Metric-dimension Encoders)

Specifications – TRD-S(H) series

Electrical Specifications				
Model		TRD-Sxxxx-BD TRD-SHxxxxBD (open collector)	TRD-Sxxxx-VD TRD-SHxxxxVD (line driver)	
Power Supply	Operating Voltage *	12–24 VDC (nominal) * Range: 10.8–26.4 VDC	5VDC (nominal) * Range: 4.75–5.25 VDC	
	Allowable Ripple	3% max.	150 mA max.	
	Current Consumption	50 mA max.		
Signal Waveform		Quadrature + home position		
Max. Response Frequency		200kHz		
Operating Speed		(max response frequency / resolution) x 60		
Duty Ratio		50% ±25%		
Phase Difference Width		25% ±12.5%		
Signal Width at Home Position		100 ± 50%		
Output	Rise/Fall Time		1µs max. (when cable length is 1m)	–
	Output Type		NPN open collector output, sinking	Line driver output (26C31 or equivalent)
	Output Logic		Negative logic (active low)	Negative logic (active high)
	Output Voltage	H	–	2.5 V min.
		L	0.4 V max.	0.5 V max.
	Current		30mA max.	20 mA max.
	Load Power Voltage		35 VDC max.	–
Short-Circuit Protection		Between output and power supply		
* To be supplied by Class II source				
Mechanical Specifications				
Starting Torque	0.001 Nm (.00074 ft./lbs) max			
Max. Allowable Shaft Load	Radial: 20N (4.5 lbs) Axial: 10N (2.25 lbs)			
Max. Allowable Speed	6000 rpm (highest speed that can support the mechanical integrity of encoder)			
Wire Size	AWG26			
Mounting Orientation	can be mounted in any orientation			
Weight	approx. 150g (5.3 oz) with 2m cable			
Environmental Specifications				
Ambient Temperature	-10 to 70°C; 14 to 158°F			
Storage Temperature	-25 to 85°C; -13 to 185°F			
Operating Humidity	35–85% RH			
Withstand Voltage	500VAC (50/60Hz) for one minute			
Insulation Resistance	50MΩ min.			
Vibration Resistance	durable for one hour along three axes at 10 to 55 Hz with 0.75 amplitude			
Shock Resistance	11 ms with 490 m/s ² applied three times along three axes			
Protection	IP40			

Encoder Accessories – Couplings

Encoder Couplings

Couplings provide a connection between solid-shaft encoders and solid shafts. We offer aluminum, fiberglass, and polymer couplings for metric, S.A.E. and metric-to-S.A.E. applications.

Misalignment compensation

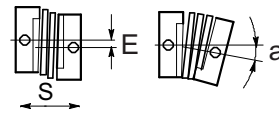

Couplings Selection Guide and Dimensions																
Type	Part Number	Price	Applicable Encoders (shaft size)	Shaft Diameter		D	L	F	C	M	a	E	S	Working Torque	Torsional Rigidity	Material
				d1	d2											
				(mm [in])							max					
Fiberglass (metric)	GJ-4D	<--->	TRD-MX (4mm)	4mm	4mm	13 [0.51]	21 [0.83]	5.3 [0.21]	3 [0.12]	M3 set screw	5°	0.4 [0.02]	0.4 [0.02]	0.6 N·m	6N·m/rad	Glass-fiber reinforced resin
	GJ-6D	<--->	TRD-S (6mm)	6mm	6mm	15 [0.59]	22 [0.87]	5.2 [0.20]	3 [0.12]	M3 set screw	6°	0.5 [0.02]	0.12 [0.005]	0.8 N·m	10 N·m/rad	
	GJ-8D	<--->	TRD-N/NA (8mm)	8mm	8mm	19 [0.75]	24 [0.94]	6.8 [0.27]	3.5 [0.14]	M4 set screw	5°	0.5 [0.02]	0.4 [0.016]	1.5 N·m	20 N·m/rad	
	GJ-10D	<--->	TRD-GK (10 mm)	10 mm	10 mm	22 [0.87]	26 [1.02]	7.1 [0.28]	4 [0.16]	M4 set screw	5°	0.5 [0.02]	0.12 [0.005]	2.0 N·m	32 N·m/rad	
Fiberglass (SAE)	GJ-635D	<--->	TRDA-2E (0.25 in)	0.25 in	0.25 in	15 [0.59]	22 [0.87]	5.2 [0.20]	3 [0.12]	M3 set screw	5°	0.5 [0.02]	0.12 [0.005]	0.8 N·m	10 N·m/rad	Glass-fiber reinforced resin
	GJK-953D	<--->	TRDA-20/25 (0.375 in)	0.375 in	0.375 in	25 [0.98]	32 [1.26]	7.3 [0.29]	3.5 [0.14]	M4 set screw	5°	0.5 [0.02]	0.12 [0.005]	2.0 N·m	32 N·m/rad	
Polymer (SAE)	STP-MTRA-SC-1412	<--->	TRDA-2E (0.25 in)	0.25 in	0.50 in	25 [0.98]	38 [1.50]	9.9 [0.39]	5.4 [0.21]	M3 cap screw	5°	0.3 [0.01]	0.12 [0.005]	3.7 N·m	0.36 °/lb·in	Engineered polymer
	STP-MTRA-SC-3812	<--->	TRDA-20/25 (0.375 in)	0.375 in	0.50 in	25 [0.98]	38 [1.50]	9.9 [0.39]	5.4 [0.21]	M3 cap screw	5°	0.3 [0.01]	0.12 [0.005]	3.7 N·m	0.36 °/lb·in	
Aluminum (metric)	ARM-075-5-4D	<--->	TRD-MX (4mm)	4mm	5mm	19.1 [0.75]	19.1 [0.75]	4.6 [0.18]	2.4 [0.09]	M3 set screw	5°	0.25 [0.01]	0.25 [0.01]	2.3 N·m	8.2 N·m/rad	Aluminum alloy
	RU-075D	<--->	TRD-S (6mm)	6mm	6mm	19.1 [0.75]	19.1 [0.75]	4.6 [0.18]	2.4 [0.09]	M3 set screw	5°	0.25 [0.01]	0.12 [0.005]	1.0 N·m	8.2 N·m/rad	
	JU-100D	<--->	TRD-N/NA (8mm)	8mm	8mm	25.4 [1.00]	25.4 [1.00]	6.6 [0.26]	3.8 [0.15]	M5 set screw	5°	0.25 [0.01]	0.25 [0.010]	1.6 N·m	14.3 N·m/rad	
	RU-100D	<--->	TRD-GK (10 mm)	10 mm	10 mm	25.4 [1.00]	25.4 [1.00]	6.6 [0.26]	3.8 [0.15]	M5 set screw	5°	0.25 [0.01]	0.12 [0.005]	1.6 N·m	14.3 N·m/rad	
Aluminum (metric-to-SAE)	ML13P-4-476D	<--->	TRD-MX (4mm)	4mm	0.1875 in	13 [0.51]	19 [0.75]	5.5 [0.22]	2.5 [0.10]	M2 set screw	5°	0.4 [0.02]	0.2 [0.01]	0.25 N·m	44 N·m/rad	Aluminum alloy (Bent plate: Polymide)
	ML16P-4-635D	<--->	TRD-MX (4mm) TRDA-2E (0.25 in)	4mm	0.25 in	16 [0.63]	23 [0.91]	7 [0.28]	3 [0.12]	M3 set screw	5°	0.6 [0.02]	0.3 [0.01]	0.4 N·m	70 N·m/rad	
	MCGL16-6-635	<--->	TRD-S (6mm) TRDA-2E (0.25 in)	6mm	0.25 in	16 [0.63]	23.2 [0.91]	7 [0.28]	3 [0.12]	M3 set screw	3.5°	0.3 [0.01]	0.3 [0.01]	0.4 N·m	70 N·m/rad	
	MCGL20-8-635	<--->	TRD-N/NA (8mm) TRDA-2E (0.25 in)	8mm	0.25 in	20 [0.79]	26 [1.02]	7.5 [0.30]	3.7 [0.15]	M3 set screw	3.5°	0.3 [0.01]	0.4 [0.02]	0.6 N·m	130 N·m/rad	
	MCGL20-8-952	<--->	TRD-N/NA (8mm) TRDA-20/25 (0.375 in)	8mm	0.375 in	20 [0.79]	26 [1.02]	7.5 [0.30]	3.7 [0.15]	M3 set screw	3.5°	0.3 [0.01]	0.4 [0.02]	0.6 N·m	130 N·m/rad	
	MCGL25-10-635	<--->	TRD-GK (10 mm) TRDA-2E (0.25 in)	10 mm	0.25 in	25 [0.98]	30.2 [1.19]	9 [0.35]	4 [0.16]	M4 set screw	3.5°	0.3 [0.01]	0.5 [0.02]	1.4 N·m	240 N·m/rad	
	MCGL25-10-952	<--->	TRD-GK (10 mm) TRDA-20/25 (0.375 in)	10 mm	0.375 in	25 [0.98]	30.2 [1.19]	9 [0.35]	4 [0.16]	M4 set screw	3.5°	0.3 [0.01]	0.5 [0.02]	1.4 N·m	240 N·m/rad	
Aluminum (SAE)	ARM-075-635-635D	<--->	TRDA-2E (0.25 in)	0.25 in	0.25 in	19.1 [0.75]	19.1 [0.75]	4.6 [0.18]	2.4 [0.09]	M3 set screw	5°	0.25 [0.01]	0.25 [0.01]	1.0 N·m	8.2 N·m/rad	Aluminum alloy
	ARM-100-9525-9525D	<--->	TRDA-20/25 (0.375 in)	0.375 in	0.375 in	25.4 [1.00]	25.4 [1.00]	6.6 [0.26]	3.8 [0.15]	M5 set screw	5°	0.25 [0.01]	0.25 [0.01]	1.6 N·m	14.3 N·m/rad	

* mm ÷ 25.4 = inches

Encoder Accessories – Couplings

Encoder Couplings – Dimensions

GJ-xxD Fiberglass Couplings (metric) & GJx-xxxD Fiberglass Couplings (SAE)

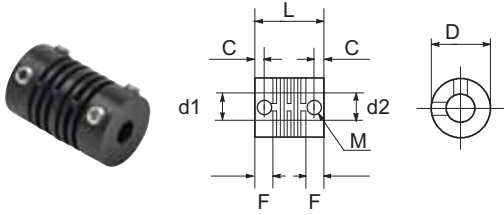

STP-MTRA-SC-xxxx Polymer Couplings

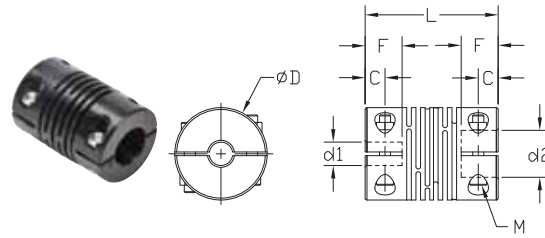

ARM-xxxxxD Aluminum Couplings (metric & SAE)

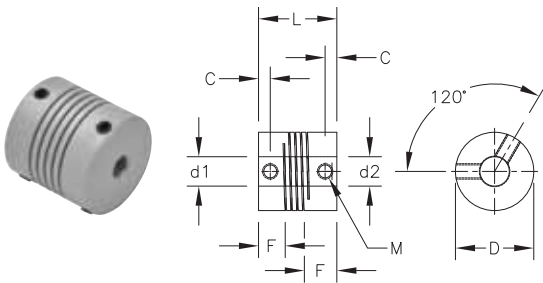

MCGLx Aluminum Couplings & ML1xP-4-xxxD Aluminum Couplings

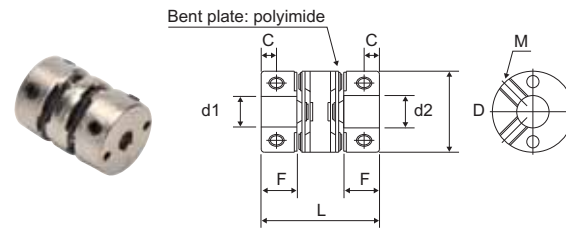

RU-075D, RU-100D, and JU-100D Aluminum Couplings

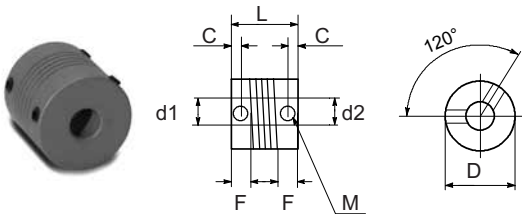

Great Encoder Selection at Great Prices



Koyo®

	Duty	Family	Size	Encoder diameter	Shaft diameter	Solid or Hollow Shaft	Operating Voltage (VDC) and Electrical Output*	IP Rating	Max Radial Load (N)	Max Axial Load (N)	Available resolutions
Incremental	Light Duty	TRD-MX	10	25mm	4mm	solid	5V Line Driver or 5-12V OC or 12-24V OC	IP50	10	5	100, 360, 500, 1000, 1024
		TRDA-2E	15	1.5"	1/4"	solid	5V Line Driver or 12-24V OC	IP50	30	20	100, 360, 500, 1000, 1024, 2500
		TRD-S	15	38mm	6mm	solid	5V Line Driver or 12-24V OC	IP40	20	10	100, 200, 250, 300, 360, 400, 500, 600, 800, 1000, 1024, 1200, 2000, 2500
		TRD-SH	15	38mm	8mm	hollow	5V Line Driver or 12-24V OC	IP40	20	10	100, 200, 250, 300, 360, 400, 500, 600, 800, 1000, 1024, 1200, 2000, 2500
	Medium Duty	TRDA-20	20	2"	3/8"	solid	5V Line Driver or 5-30V P/P	IP50	50	30	100, 360, 500, 1000, 1024, 2500
		TRDA-25	25 (w/size 20 body)	2.5" flange (w/ 2.0" body)	3/8"	solid	5V Line Driver or 5-30V P/P	IP65	50	30	100, 360, 500, 1000, 1024, 2500
		TRD-N	20	50mm	8mm	solid	5V Line Driver or 5-30V P/P	IP65	50	30	3, 4, 5, 10, 30, 40, 50, 60, 100, 120, 200, 240, 250, 300, 360, 400, 480, 500, 600, 750, 1000, 1024, 1200, 2000, 2500, 3000, 3600, 5000
		TRD-NH	20	50mm	8mm	hollow	5V Line Driver or 5-30V P/P	IP65	50	30	3, 4, 5, 10, 30, 40, 50, 60, 100, 120, 200, 240, 250, 300, 360, 400, 480, 500, 600, 750, 1000, 1024, 1200, 2000, 2500, 3000, 3600, 5000
	Heavy Duty	TRD-GK	30	78mm	10mm	solid	10-30V P/P	IP65	100	50	30, 100, 120, 200, 240, 250, 300, 360, 400, 500, 600, 800, 1000, 1200, 1500, 1800, 2000, 2500, 3600, 5000
	Medium Duty Absolute	TRD-NA	20	50mm	8mm	solid	10-30V OC	IP65	50	30	32, 64, 128, 180, 256, 360, 512, 720, 1024 (grey code)

All our encoders feature an integral 2m cable except for the TRDA-25 series which has an MS connector

*Operating Voltage and Electrical Output:
 • LD = Line Driver (all Line Drivers require 5VDC supply)
 • OC = NPN Open Collector (at Operating Voltage)
 • P/P = Push Pull or Totem Pole (at Operating Voltage)

Accessories

Couplings

A variety of couplings - metric-to-metric, inch-to-inch (SAE - SAE), and metric-to-inch are in stock, ready to ship.



Flanges

A collection of flanges that ease encoder mounting. Several models are available with round flanges, square flanges and miscellaneous mounting options.

Mounting brackets

Simplify your installation with a ready-to-use right-angle mounting bracket for light, medium and heavy-duty encoders



Cables

For encoders that require a connector cable, we have cables in stock, priced right and ready to ship.



- Company Information
- Systems Overview
- Programmable Controllers
- Field I/O
- Software
- C-more & other HMI
- Drives
- Soft Starters
- Motors & Gearbox
- Steppers/Servos
- Motor Controls
- Proximity Sensors
- Photo Sensors
- Limit Switches
- Encoders
- Current Sensors
- Pressure Sensors
- Temperature Sensors
- Pushbuttons/Lights
- Process
- Relays/Timers
- Comm.
- Terminal Blocks & Wiring
- Power
- Circuit Protection
- Enclosures
- Tools
- Pneumatics
- Safety
- Appendix
- Product Index
- Part # Index